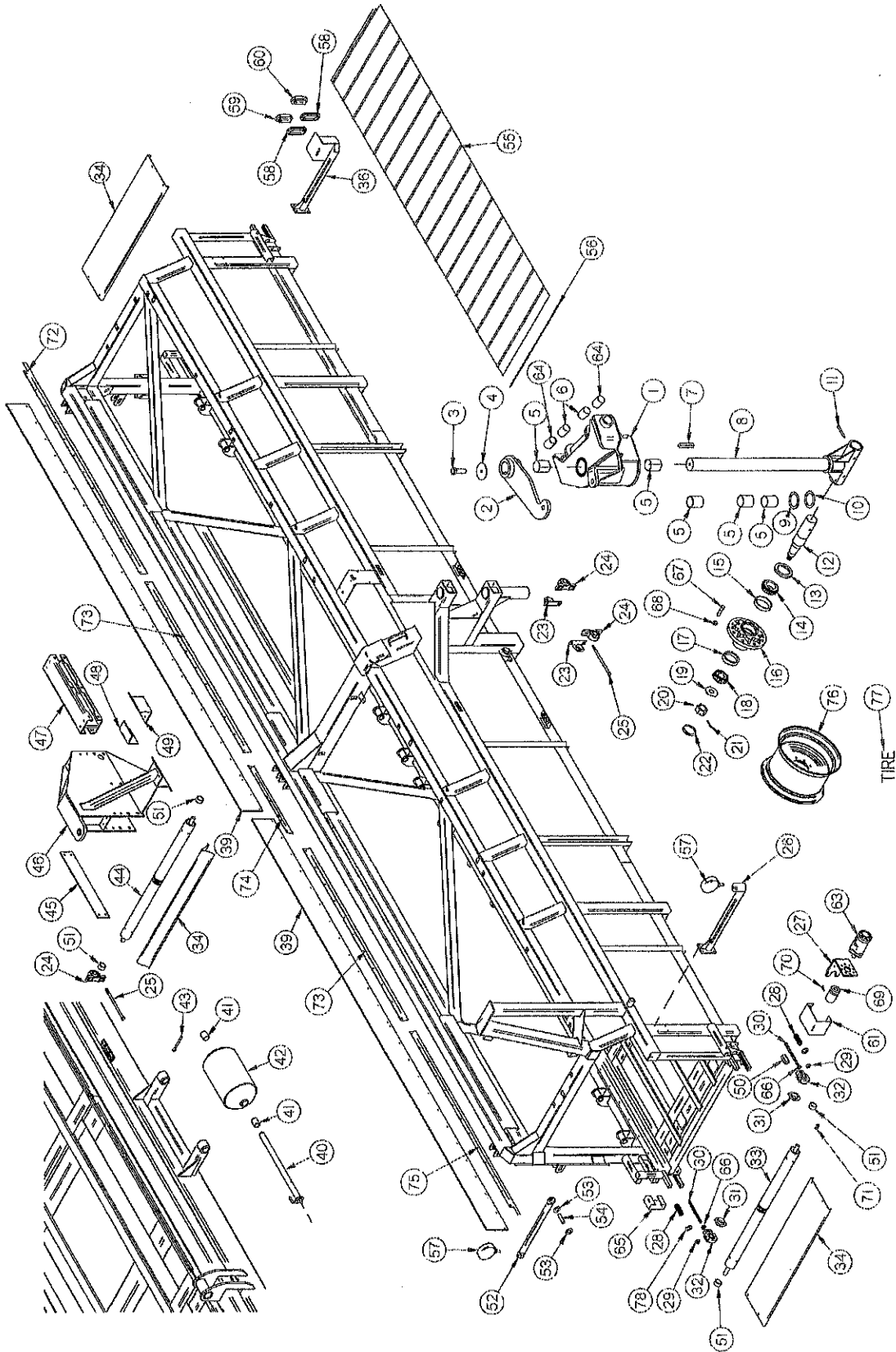

FIGURE 1
FRAME

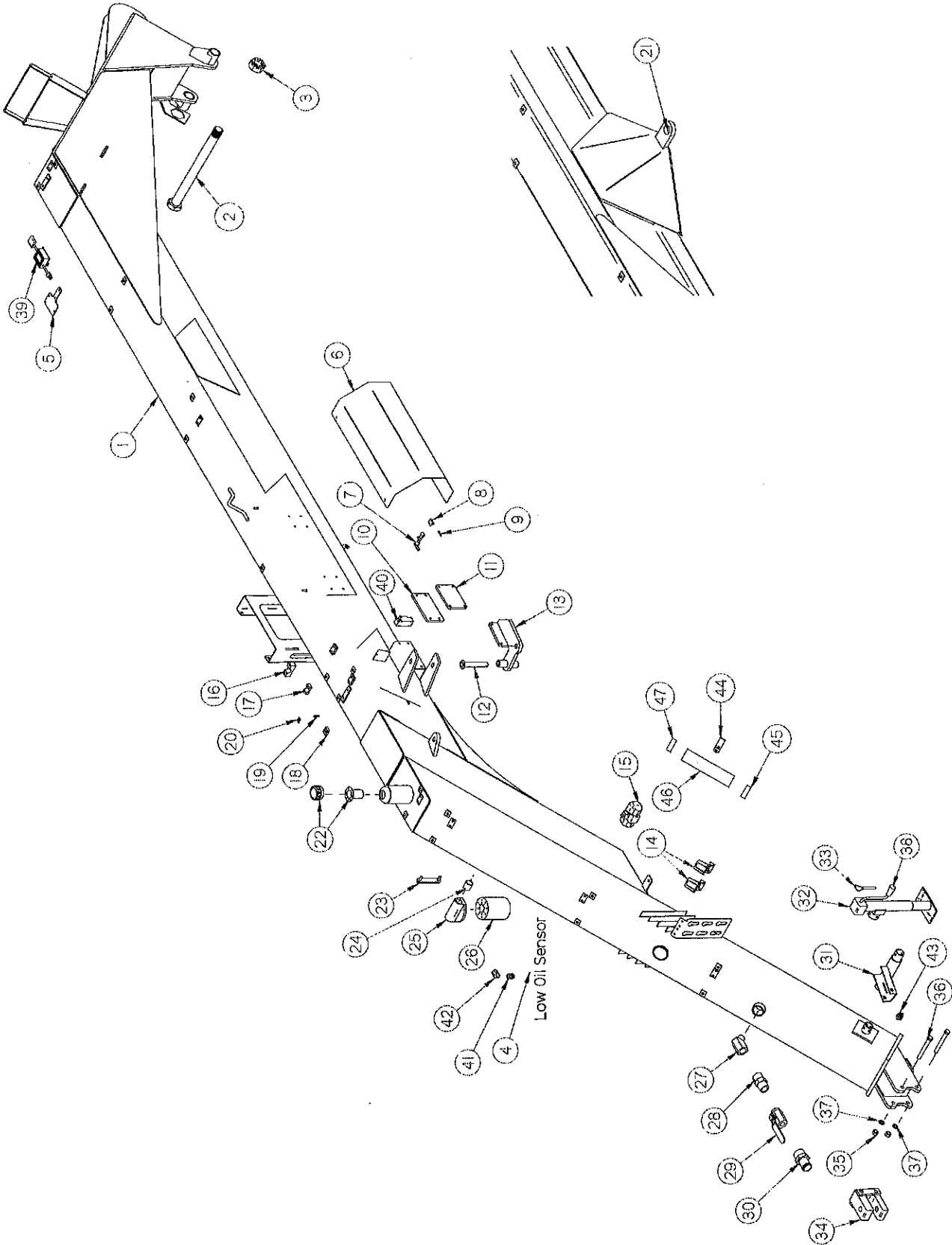

**FIGURE 1
FRAME**

ITEM	PART NO.	DESCRIPTION	ITEM	PART NO.	DESCRIPTION
1.	CHM3	Steering Pivot	41.	RG132	Bushing (1.26 IDx1.50 ODx2")
2.	CHM4	Steering Flange	42.	FM12	Drum Roller
3.	RG135	1/2" X 1" Bolt Gr. 5	43.	3G22	Expansion Pin 5/16" X 1-3/4"
4.	CHM5	Top Washer	44.	DWM13	Middle Roller
5.	CHM148	Bushing (Phenolic)	45.	CHM21	Slider Poly .250
6.	RG26	Bushing 2.015 ID x 2.25 OD x 2"	46.	CHM22	Pole Slider
7.	DWM126	1/2" X 2-1/2" Key	*	CHM23	Bushing (Spherical)
8.	CHM6	Steering Fork	47.	CHM24	Cylinder Mount
9.	DWM49	Steel Washer 3" ID	48.	CHM25	Slider Poly Short .250
10.	DWM73	Bronze Washer 3" ID	49.	CHM26	Short Pole Slider
11.	CHM7	3/8" X 3-1/2" Bolt Gr. 5	50.	CHM27	3/4" Nut
12.	CHM8	Spindle	51.	DWM57	Pipe Spacer
13.	RG165	Seal	52.	CHM131	Timing Link
14.	RG166	Bearing	53.	CHM139	Timing Link Washer
15.	RG167	Race	54.	CHM140	Timing Link Pin
16.	RG168	Hub	55.	DWM160	Cross Conveyor Belt
17.	RG169	Race	56.	DWM162	Cross Conveyor Lacing Pin
18.	RG170	Bearing	*	DWM318	Repair Dutchman
19.	RG183	Washer	*	DWM162	Cross Conveyor Lacing
20.	RG184	Nut	57.	DWM129	Yellow Hazard Light
21.	RG185	Cotter Pin 7/32" X 2"	58.	S308	Rubber Light Mount
22.	RG171	Hub Cap	59.	S310	Red Tail Light
23.	CHM9	Anti - Wrap Guard	60.	S309	Yellow Tail Light
24.	DWM132	Bearing (Pillow Block)	61.	CHM133	Motor Shield
25.	CHM304	1/2" X 8-1/2" Bolt Gr.	63.	CHM149	Hydraulic Motor
26.	CHM10	Right Front Light Bracket	64.	CHM150	Bushing 2.015" IDx2.25" ODx2"
27.	CHM11	Torque Arm	65.	CHM 310	Bearing Shield
28.	CHM12	Spring	66.	DWM169	3/4" Jam Nut
29.	CHM13	3/4" Square Nut	67.	RG71	Stud Bolt
30.	CHM14	Takeup Shaft	68.	RG72	Lug Nut
31.	CHM15	Anti - Wrap	69.	DWM27	Coupler
32.	CHM16	Bearing (Complete)	70.	DWM137	Cap Screw - Coupler
33.	CHM313	Drive Roller	71.	G23	5/16" X 1-3/8" Key
34.	CHM311	Conveyor Hay Shield	72.	DWM335	RH Skirt
36.	CHM18	Left Rear Light Bracket	73.	DWM46	Short Skirt
39.	DWM350	Poly Skirt	74.	DWM47	Middle Skirt
40.	CHM20	Frame Roller Pin	75.	DWM334	LH Skirt
			76.	CHM102	Wheel W-523360R
			77.	CHM327	Tire 13.50 X 15 FI
			78.	T73	Washer

NOTE: *(Means Not Shown)

FIGURE 2



**FIGURE 2
POLE**

ITEM	PART NO.	DESCRIPTION	ITEM	PART NO.	DESCRIPTION
1.	CHM28	Pole	25.	DWM82	Filter Base
2.	CHM29	Pole Pin	26.	STM23	Filter
3.	CHM30	2" Nut	27.	DWM267	Street Elbow 2" - 45°
4.	CHM31	Low Oil Sensor	28.	DWM147	2" Nipple Nut
5.	CHM32	Module Holder	29.	DWM83	Ball Valve
6.	CHM33	Pole Valve Shield	30.	DWM144	2" Hose Barb
7.	X192	Rubber Latch	31.	CHM44	Pump Storage Bracket LH
8.	X194	Latch Mounting Bracket	*	CHM308	Pump Storage Bracket RH
9.	X195	Latch Pin	32.	DWM124	Jack (2000#)
10.	CHM34	Latch Standoff Poly	33.	BFR4	Jack Pin & Chain
11.	CHM35	Latch Face Plate Poly	34.	WM43	Hitch - Adjustable
12.	CHM36	Latch Pin	35.	DWM282	3/4" Nut
13.	CHM37	Latch Bar	36.	50N129	3/4" X 6" Bolt Gr. 5
14.	CHM38	Plug Storage	37.	RG199	3/4" Lock Washer
15.	DWM130	Flood / Worklight	38.	12N12	Jack Handle
16.	CHM39	1-1/4" Line Clamp (Complete)	39.	S441	Light Module
17.	CHM40	3/4" Line Clamp (Complete)	40.	LW78	Limit Switch
18.	CHM41	3/8" Line Clamp Double (Complete)	41.	LW178	Strain Relief
19.	CHM42	Line Clamp Extender Dbl. Line	42.	CHM67	Pull Elbow 90°
20.	CHM43	Line Clamp Spacer Dbl. Line	43.	DWM159	Drain Plug
21.	CHM23	Bushing (Spherical)	44.	S416	Hanger Bracket
22.	DWM81	Strainer Filler	45.	S418	Cap W/Hole
23.	DWM204	Temp. & Oil Level Gauge	46.	S415	Tube
24.	CHM132	1-1/4" Nipple Nut	47.	S414	Cap

NOTE: * (Means Not Shown)

**FIGURE 3
PICKUP**

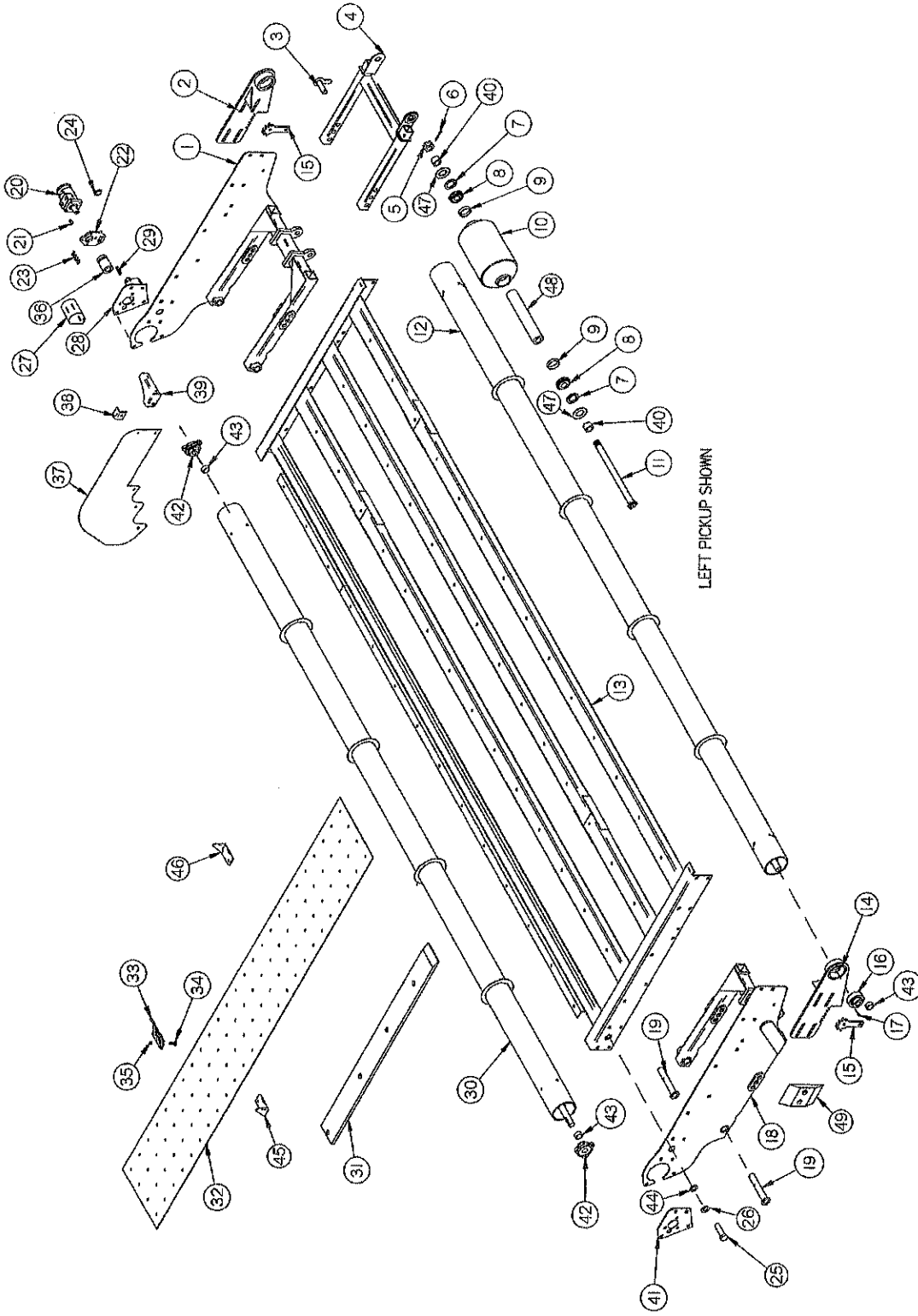

FIGURE 3 PICKUP

ITEM	PART NO.	DESCRIPTION	ITEM	PART NO.	DESCRIPTION
1.	CHM46	Left Side Panel	26.	CHM61	Pivot Washer
2.	CHM47	Pickup Belt Tightener A	27.	CHM62	Motor Coupler Shield
3.	CHM312	Head Roller Slideout Pin Long	28.	CHM63	Drive Roller Bearing Bracket Left
4.	CHM49	Head Roller Slideout Frame	*	CHM64	Drive Roller Bearing Brkt.Right
5.	BFR228	Slotted Nut 1-1/4-12	29.	G23	5/16" X 1-3/8" Key
6.	T56	Cotter Pin 5/32" X 2"	30.	CHM65	Pickup Drive Roller
7.	G34	Seal	31.	DWM358	Slides
8.	G18	Bearing	32.	DWM359A	Pickup Belt Section
9.	G54	Race	*	DWM364A	Complete Belt W/Teeht & Pin
10.	CHM50	Head Roller	*	DWM367	Repair Dutchman Assembly
11.	CHM51	Head Roller Pin	*	DWM373	Complete Dutchman Repair
12.	CHM52	Pickup Idler Roller	-	- -	Kit w/Nuts Bolts and Clips
13.	CHM53	Belt Frame	33.	SWM1	Pickup Tooth
14.	CHM54	Pickup Belt Tightener B	34.	SWM26	Bolt
15.	CHM55	Tightener Pinion	35.	SWM27	Nut
16.	CHM56	Bearing (HCC207-20)	36.	DWM27	Coupler
17.	CHM57	Grease Zerk (1680)	37.	CHM66	Pickup Poly Shield
18.	CHM58	Right Side Panel	38.	CHM68	Poly Shield Holder
19.	CHM59	Head Pivot Pin	39.	CHM70	Poly Shield Bracket Left
20.	DWM84	Hydraulic Motor (101-3048)	*	CHM69	Poly Shield Bracket Right
*	WM225	Seal Kit	40.	CHM45	Bushing
21.	5B10	Woodruff Key 1/4" X 1"(Hardened)	41.	CHM130	Drive Roller Bearing Bracket
22.	CHM306	Motor Mount B	42.	SWM35	3-Bolt Bearing Assembly
23.	DWM137	Cap Screw - Coupler	43.	WM27	Lock Collar
24.	F56	Lynch Pin	44.	WM183	Pivot Bushing
25.	DWM177	1" X 2-1/2" Full Thread Bolt Gr. 5	45.	CHM317	Right Tooth
			46.	CHM316	Left Tooth
			47.	CHM305	Guage Wheel Seal Washer
			48.	CHM315	Roller Grease Spacer
			49.	CHM307	Head Spacer Poly Block

NOTE: * (MEANS NOT SHOWN)

FIGURE 4
CROP ROLLER / WINDGUARD

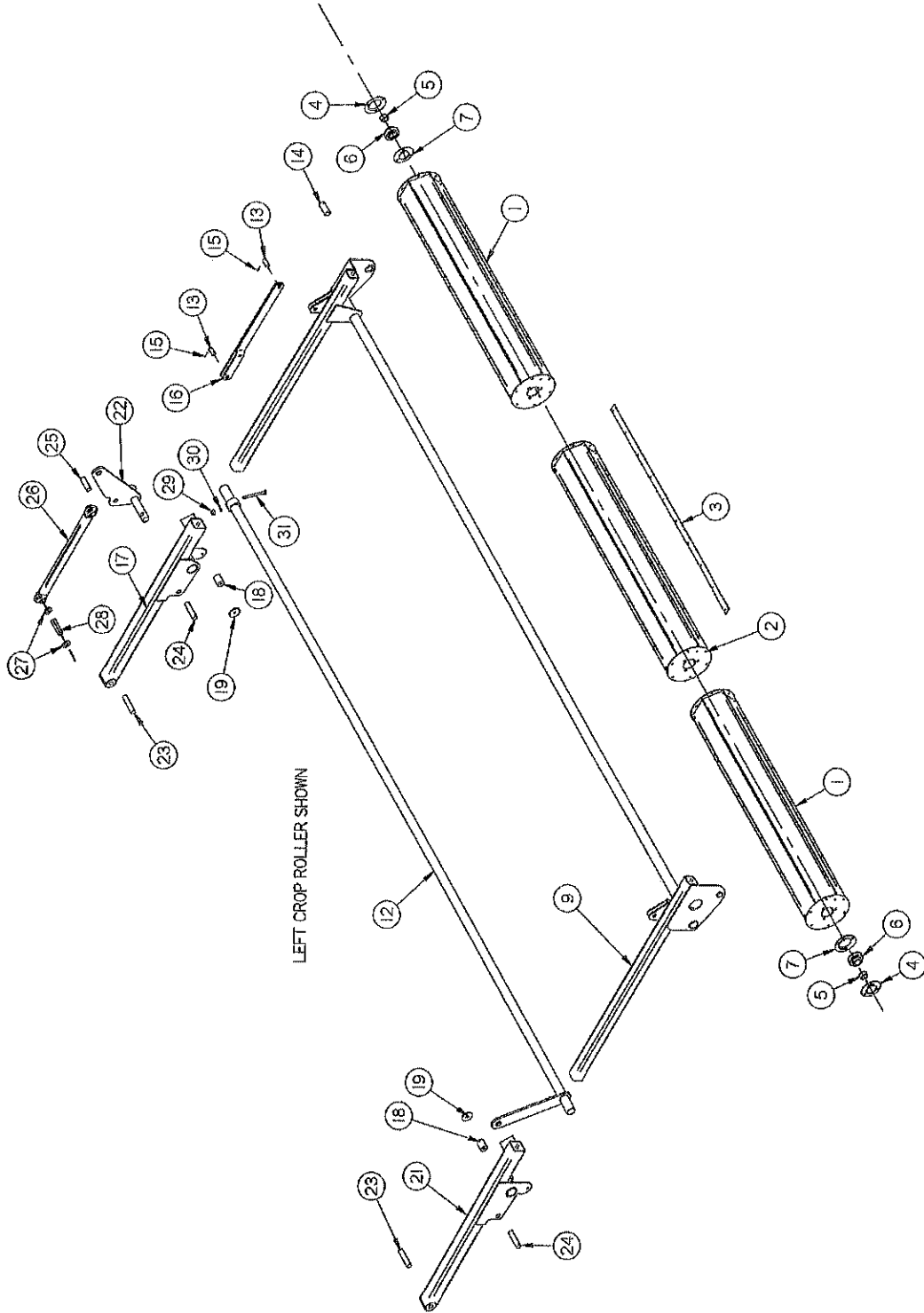
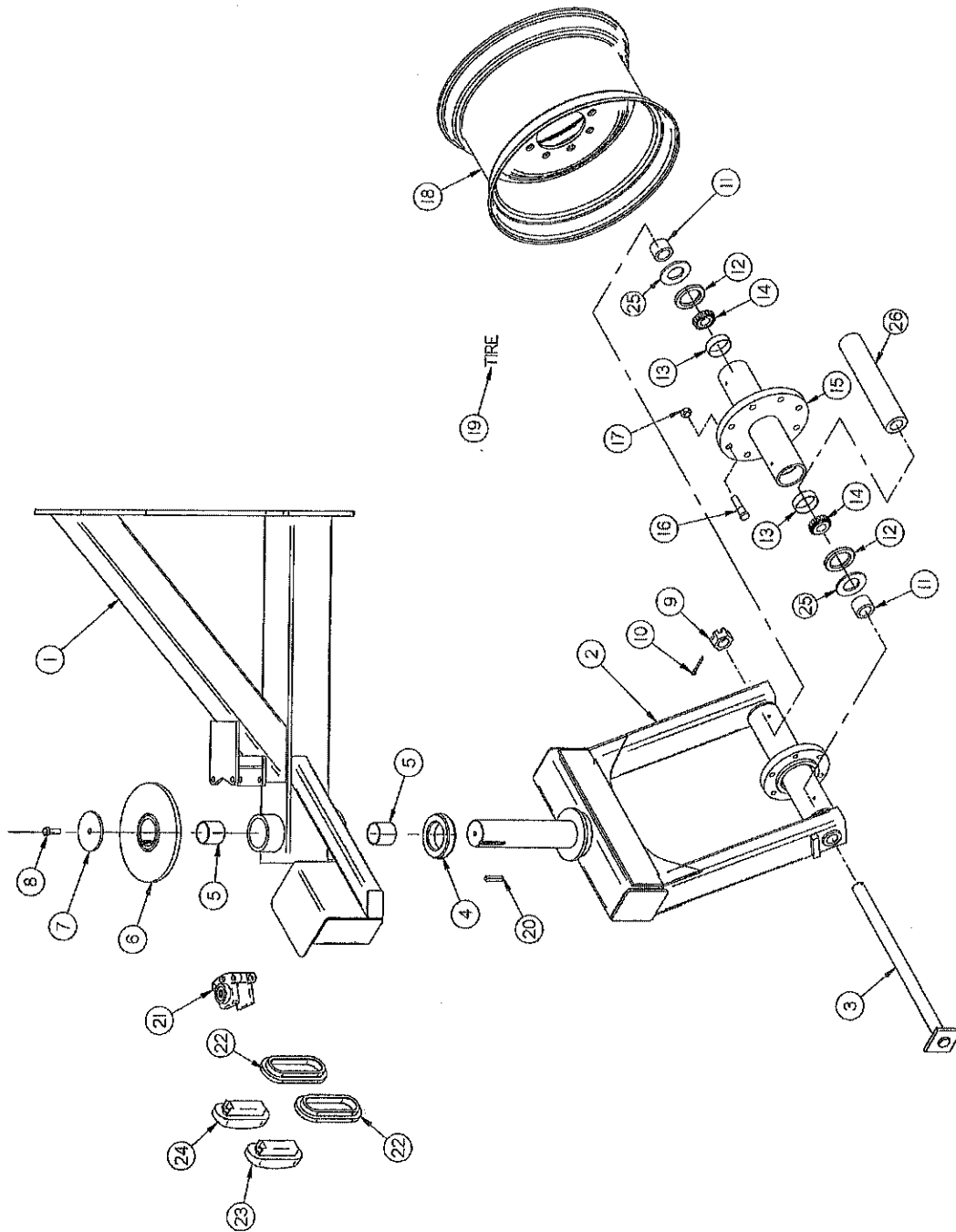

FIGURE 4
CROP ROLLER / WINDGUARD

ITEM	PART NO.	DESCRIPTION
1.	CHM71	Crop Roller End
2.	CHM72	Crop Roller
3.	CHM73	Crop Roller Rubber
4.	F114A	Bearing Flange 45° Zerk
5.	F16	Lock Collar
6.	F115	Bearing 1-1/4"
7.	F14	Bearing Flange
9.	CHM76	Inner Sleeve Left
*	CHM75	Inner SleeveRight
12.	CHM79	Torsion Pipe Left
13.	CHM81	Linkage Pin
14.	CHM82	Crop Roller Pivot Pin
15.	T72	Cotter Pin 5/32" X 1-1/2"
16.	CHM83	Wind Guard Link
17.	CHM84	Sleeve Pivot Tube Left
*	CHM85	Sleeve Pivot Tube Right Center
18.	CHM86	Windguard Roller
19.	16SV211	Washer
21.	CHM88	Sleeve Pivot Tube Left Center
*	CHM89	Sleeve Pivot Tube Right
22.	CHM90	Torsion Arm Left
*	CHM91	Torsion Arm Right
23.	CHM92	Pivot Pin
24.	CHM93	Cylinder Pin
25.	CHM109	Top Link Pin
26.	CHM131	Timing Link
27.	CHM139	Timing Link Washer
28.	CHM140	Timing Link Pin
29.	T68	5/8" Nut
30.	T69	5/8" Lockwasher
31.	CHM128	5/8" x 4-1/4" Bolt GR. 5

NOTE: * (MEANS NOT SHOWN)

FIGURE 5

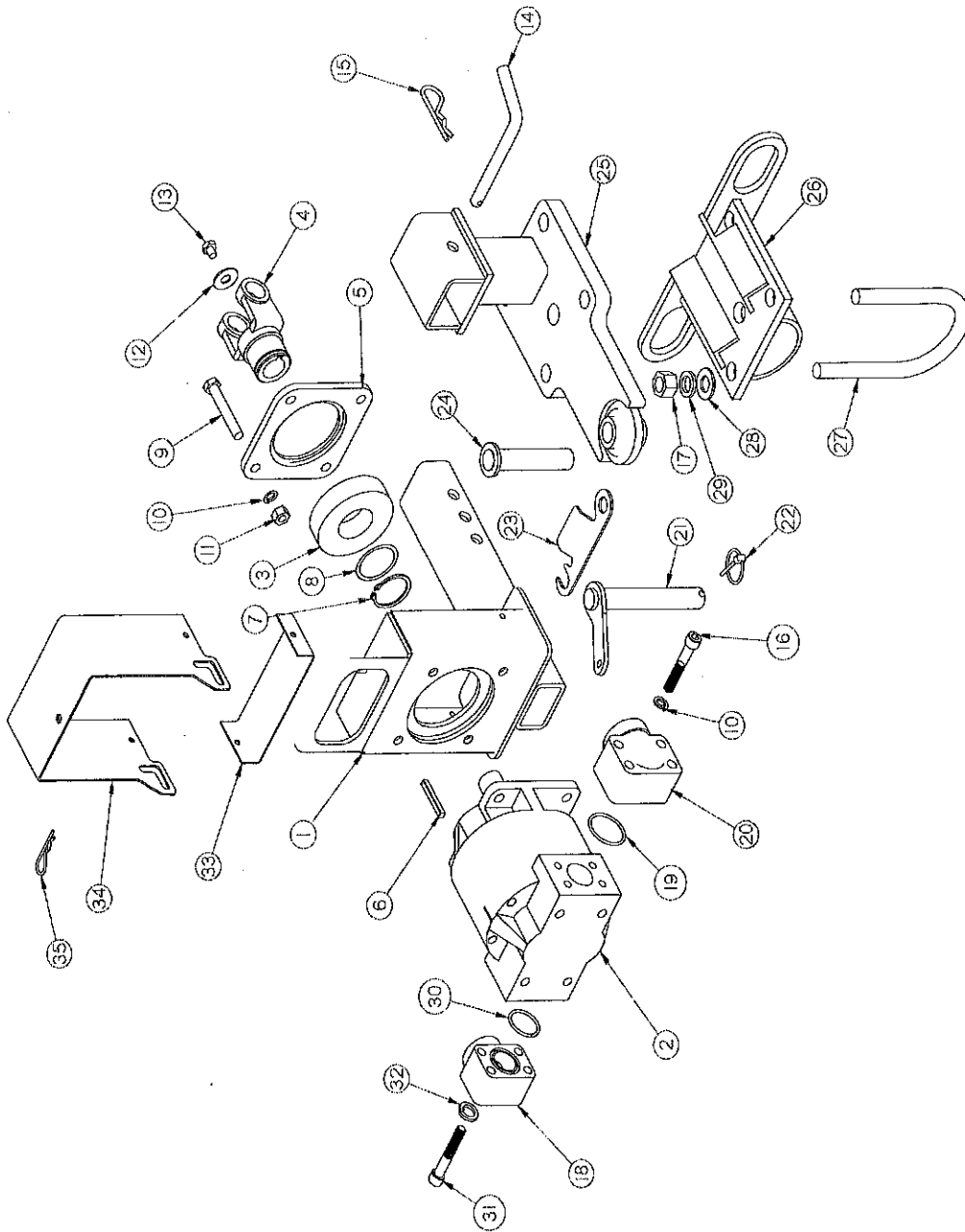

**FIGURE 5
CASTER WHEEL BRAKE**

ITEM	PART NO.	DESCRIPTION
1.	CHM94	Gauge Wheel Mount Right
*	CHM95	Gauge Wheel Mount Left
2.	CHM96	Caster
3.	CHM97	Gauge Wheel Spindle
4.	RG280	Thrust Bearing (E37)
5.	RG147	Bushing 3"OD X 2-3/4" ID X 3"
6.	CHM98	Brake Rotor
7.	CHM5	Top Washer
8.	RG135	1/2" X 1" Bolt Gr. 5
9.	BFR228	1-1/4" Slotted Nut
10.	T56	Cotter Pin 5/32" X 2"
11.	CHM45	Bushing
12.	G34	Seal
13.	G54	Race
14.	G18	Bearing
15.	CHM101	Caster Hub
16.	26G5A	Stud
17.	RG72	Nut
18.	CHM102	Wheel W-523360R
19.	CHM327	Tire 13.50 X 15 FI
20.	S38	3/8" X 2-3/8" Square Key
21.	CHM103	Brake Caliper
*	CHM104	Brake Pad
22.	S308	Rubber Light Mount
23.	S309	Yellow Tail Light
24.	S310	Red Tail Light
25.	CHM305	Gauge Wheel Seal Washer
26.	CHM314	Caster Wheel Grease Spacer

NOTE: * (MEANS NOT SHOWN)

FIGURE 6

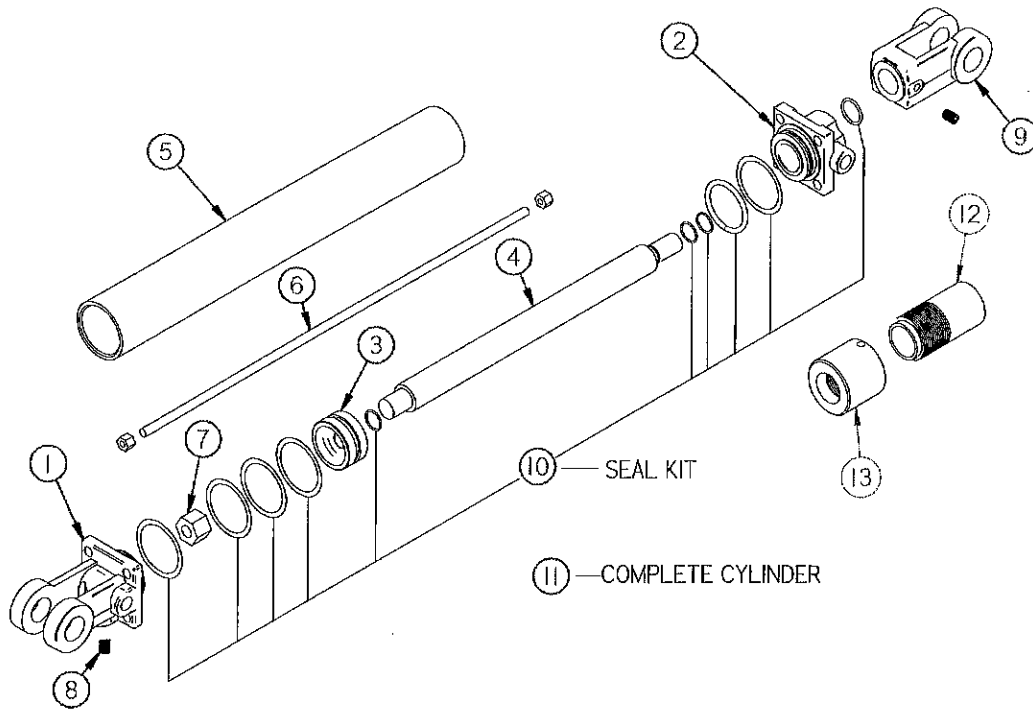

**FIGURE 6
HYDRAULIC PUMP**

ITEM	PART NO.	DESCRIPTION
1.	DWM336	Reciever Pump Mount
2.	DWM276	PTO Pump
*	DWM302	Replacement Shaft Seal
3.	DWM277	Thrust Roller Bearing
4.	DWM295	PTO Yoke (See PTO Drawing)
5.	DWM278	Outside Bearing Housing
6.	DWM279	5/16" X 2-1/4" Key(RoundEdges)
7.	DWM280	Snap Ring 2"
8.	G92	Shim (As Needed)
9.	16SV91	1/2" X3-1/4" Bolt Gr. 5
10.	R35	1/2" Lock Washer
11.	R29	1/2" Nut
12.	DWM320	1/2" Flat Washer
13.	DWM301	Bolt Metric
14.	10WR14	5" Bent Pin
15.	DWM310	Hair Pin
16.	DWM281	1/2" Socket Head Cap Screw
17.	DWM282	3/4" Nut
18.	DWM283	Pressure L - Flange
19.	DWM284	O - Ring
20.	DWM285	Return L - Flange
21.	DWM273	Draw Pin
22.	F56	Clip Pin
23.	DWM286	Drawbar Pin Lock
24.	DWM274	Hitch Pin
25.	DWM271	Hitch Extension
26.	DWM272	Hitch Plate
27.	DWM287	U - Bolt (2)
28.	DWM288	3/4" Flat Washer
29.	RG199	3/4" Lock Washer
30.	DWM311	O - Ring
31.	DWM312	7/16" Socket Head Cap Screw
32.	DWM313	7/16" Lock Washer
33.	DWM330	Lower PTO Shield
34.	DWM329	Upper PTO Shield
35.	X97	Hair Pin

NOTE: * (MEANS NOT SHOWN)

FIGURE 7

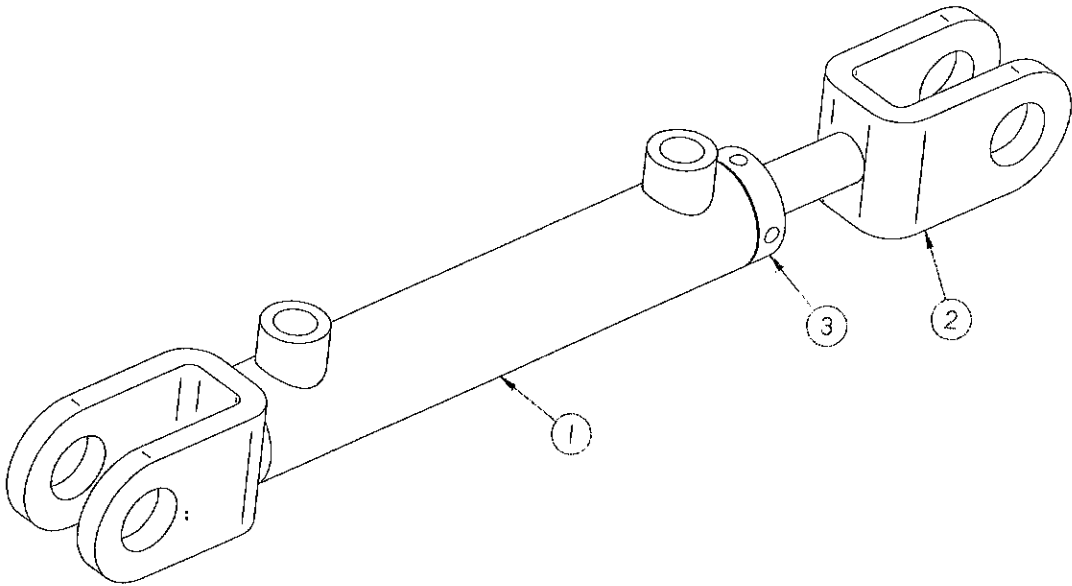

**FIGURE 7
HYDRAULIC CYLINDERS**

ITEM	PICKUP / LATCH	STEERING WINDGUARD		POLE	DESCRIPTION
	2" x 6"	2" x 8"	3" x 6"	3-1/2" x 60"	
	PART NO.	PART NO.	PART NO.	PART NO.	
1.	23N142A	"	CHM138	16SV157A	Clevis Cap
2.	23N143A	"	CHM110	HD189	Rod Cap
3.	23N144	"	CHM111	HD198	Piston
4.	CHM104	T134A	CHM112	HD191	Rod
5.	CHM105	BFR68	CHM113	HD193	Cylinder Tube
6.	CHM106	T186	CHM114	HD195	Tie Rod
7.	23N148	"	CHM115	DWM198	Piston Nut
8.	23N149	"	CHM116	DWM199	Plug
9.	23N150A	"	CHM117	DWM200	Rod Clevis
10.	23N151	"	CHM118	HD197	Seal Kit
11.	CHM107	BFR69A	CHM152&CHM108	HD136	Hydraulic Cylinder
12.	N/A	CHM134	CHM136	N/A	Cylinder Stop Inside
13.	N/A	CHM135	CHM137	N/A	Cylinder Stop Outside

NOTE: Cylinder CHM152, The Ports Are Parallel To The Pins

FIGURE 8

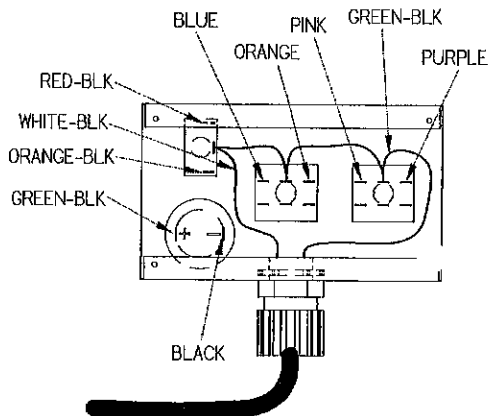
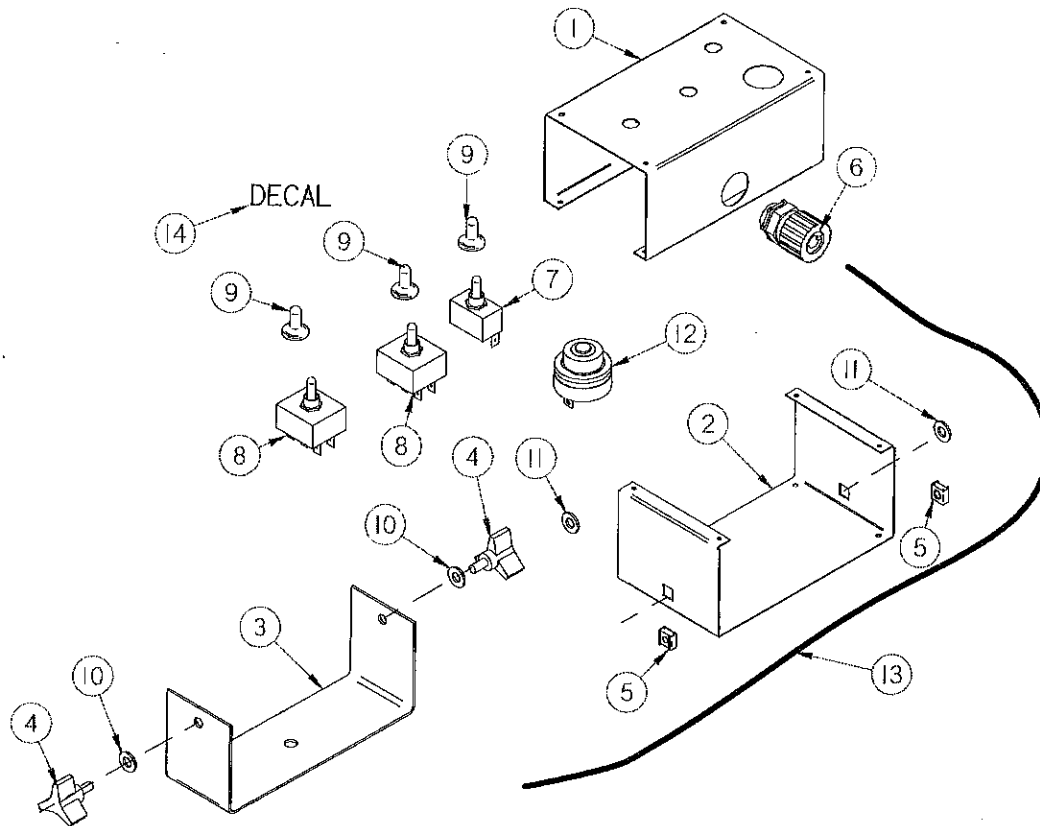

**FIGURE 8
HEAD FLOAT CYLINDER 1-1/4 x 6 (4)**

ITEM	PART NO.	DESCRIPTION
1.	CHM119	Cylinder
2.	CHM120	Cylinder Rod
3.	CHM121	Front Gland
*	CHM122	Piston
*	CHM123	Nut
<hr/>		
*	CHM124	Seal Kit
*	CHM125	Complete Cylinder

NOTE: * (MEANS NOT SHOWN)

FIGURE 9



**FIGURE 9
CONTROL BOX**

ITEM #	PART #	DESCRIPTION
1.	CHM126	Control Box Top
2.	DWM 448	Control Box Bottom
3.	DWM 449	Control Box Mount
4.	HD174	Knob
5.	HD173	Panel Nut
6.	DWM175	Strain Relief (Cord Grip)
7.	HD207	Switch (STDP MOM)
8.	DWM 453	Switch (Hesitation)
9.	16SV235	Switch Boot
10.	DWM 327	Poly Washer
11.	DWM404	Rubber Washer
12.	CHM127	Low Oil
13.	CHM1	Power Cord
14.	013107A	Decal
15.	CHM129	Complete Control Box

**FIGURE 11
FAN HARNESS**

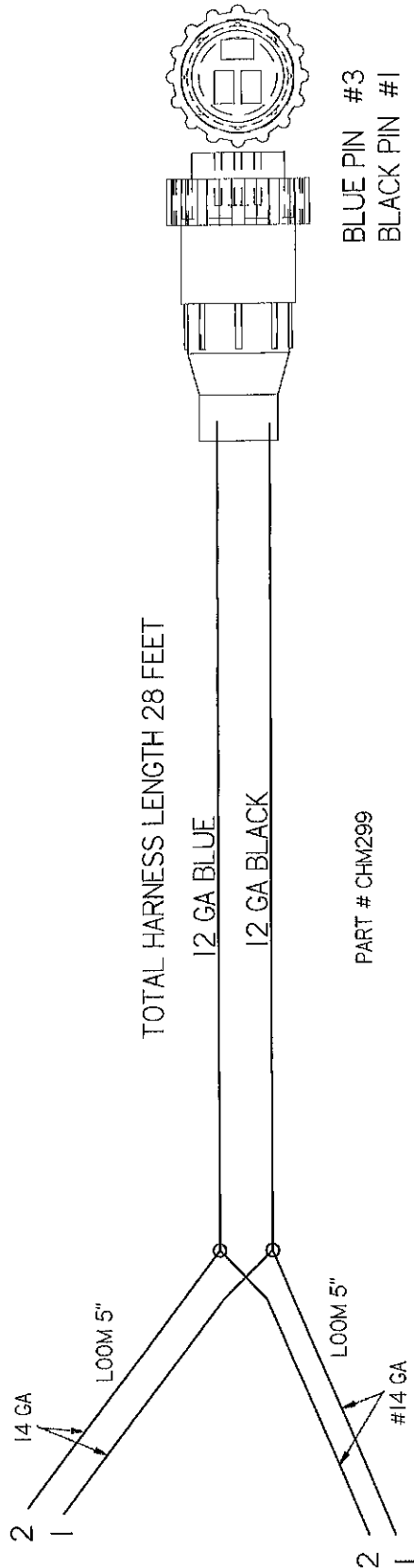
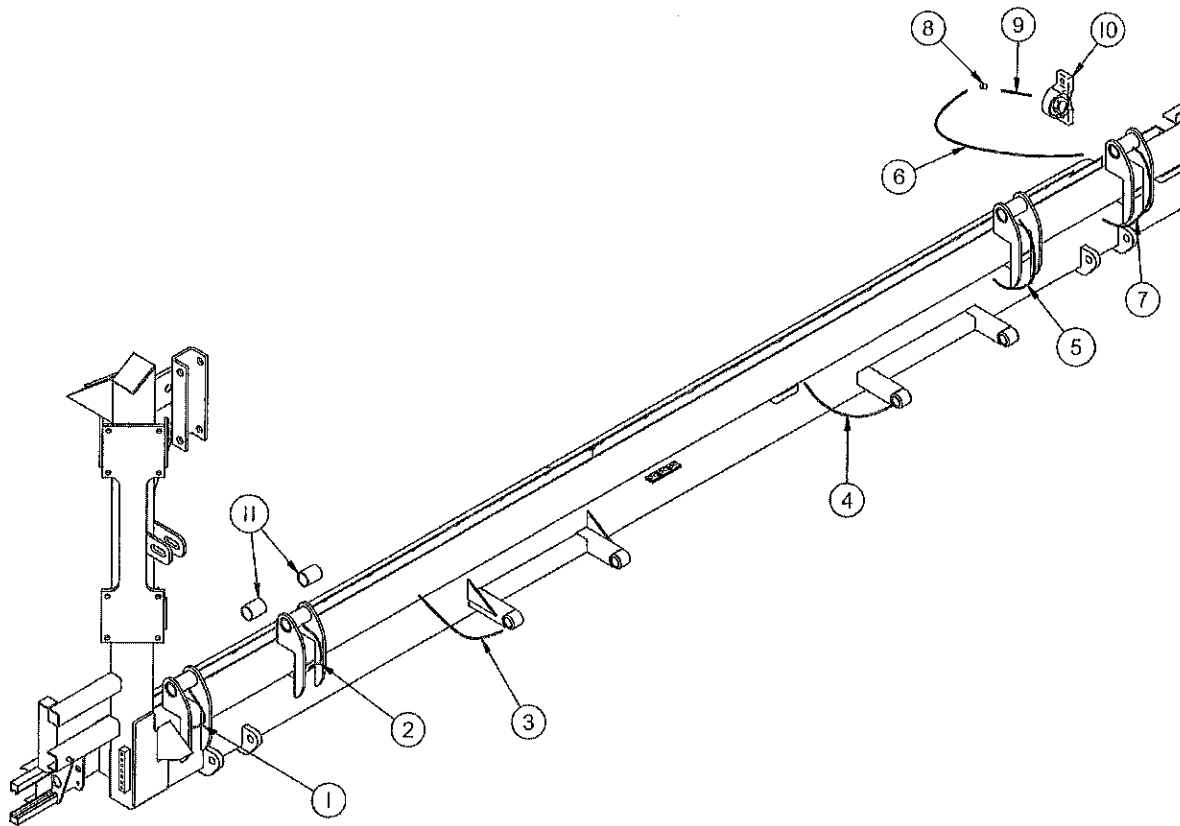

FIGURE 12

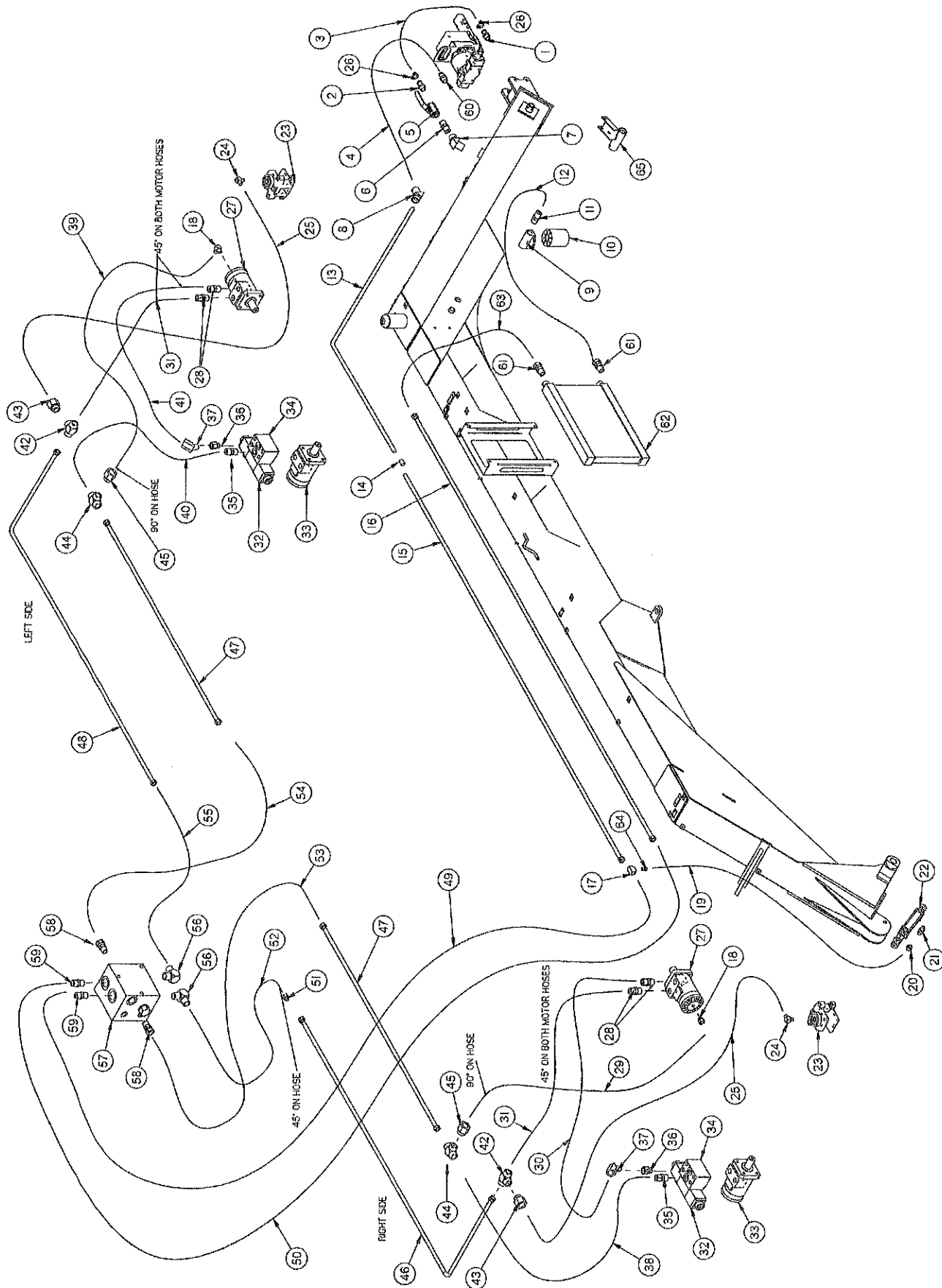

**FIGURE 12
REMOTE GREASING**

ITEM #	PART #	DESCRIPTION
1.	CHM318	Grease Line 25-1/2"
2.	CHM319	Grease Line 45-1/2"
3.	CHM320	Grease Line 79-1/2"
4.	CHM321	Grease Line 153"
5.	CHM322	Grease Line 175"
6.	CHM323	Grease Line 192"
7.	CHM324	Grease Line 195"
8.	CHM325	1/8" Coupling
9.	CHM326	1/8" X 2" Nipple
10.	DWM132	Bearing (Pillow Block)
11.	RG132	Bushing (1-1/2" OD X 1.260" ID X 2")

FIGURE 13

MOTOR CIRCUIT



**FIGURE 13
MOTOR CIRCUIT**

ITEM	PART NO.	DESCRIPTION	ITEM	PART NO.	DESCRIPTION
1.	DWM260	Hose Barb	33.	CHM149	Hydraulic Motor
2.	DWM144	2" Hose Barb (STC-25B)	34.	CHM172	Manifold
3.	CHM153	Hydraulic Hose 57"	35.	CHM173	Connector (10-8 F50X-S)
4.	CHM154	Hydraulic Hose 1" X 78"	36.	CHM174	Male/Female SAE 8-10 (F50G5-S)
5.	DWM83	Ball Valve	37.	CHM175	Elbow 45° (10 V50X-S)
6.	DWM147	2" Nipple (5404-32-32)	38.	CHM176	Hydraulic Hose 63"
7.	DWM267	2" 45° Elbow(SE45-BP-32)	39.	CHM177	Hydraulic Hose 96"
8.	CHM267	2" 45° Elbow(16V6X-S)	40.	CHM178	Hydraulic Hose 67"
9.	DWM82	Filter Base	41.	CHM179	Hydraulic Hose 140"
10.	STM23	Filter	42.	CHM180	Tee Swivel Run (12 R6X-S)
11.	CHM155	Male Connector (20FTX-S)	43.	CHM181	Reducer (12-4 TRTXN-S)
12.	CHM156	Hydraulic Hose 1-1/4" X 44"	44.	CHM182	Tee Swivel run (16 R6X-S)
13.	CHM157	Pump Pressure Tube Front	45.	CHM183	Reducer (16-6 TRTXN-S)
14.	CHM158	Connector (16HTX-S)	46.	CHM184	Hydraulic Line Right
15.	CHM159	Pump Pressure Tube Back	47.	CHM185	Hydraulic Line
16.	CHM160	Return Tube	48.	CHM186	Hydraulic Line Left
17.	CHM161	Tee (16-4 XHX6G5TP-S)	49.	CHM187	Hydraulic Hose 78"
18.	CHM162	Connector (6-4 C50X-S)	50.	CHM188	Hydraulic Hose 78"
19.	CHM163	Hydraulic Hose 90"	51.	CHM189	Union (12 HTX-S)
20.	BFR70	Vent	52.	CHM190	Hydraulic Hose 27"
21.	CHM164	Male Elbow (6-6 CTX-S)	53.	CHM191	Hydraulic Hose 30"
22.	BFR69A	Hydraulic Cylinder	54.	CHM192	Hydraulic Hose 60"
23.	CHM103	Brake Caliper	55.	CHM193	Hydraulic Hose 63"
*	CHM104	Brake Pad	56.	CHM194	Elbow (12 C50X-S)
24.	CHM165	Elbow (4 C50X-S)	57.	CHM195	Manifold
25.	CHM166	Brake Hose 74"	58.	CHM196	Connector (16-12 F50X-S)
26.	DWM122	Hose Clamp #HC200	59.	CHM197	Connector (16 F50X-S)
27.	DWM84	Pickup Motor (101-3048)	60.	CHM229	Connector (16-20 F50X)
28.	CHM167	Male Connector(8-12FTX-S)	61.	CHM297	Adapter (S20-24 FTX-S)
29.	CHM296	Hydraulic Hose 85"	62.	DWM78	Oil Cooler
30.	CHM169	Hydraulic Hose 132"	*	DWM319	Fan Assembly
31.	CHM170	Hydraulic Hose 53"	63.	CHM298	Hydraulic Hose 1-1/4" X 58"
32.	CHM171	Valve / Solenoids	64.	CHM300	Straight Connector (6-4 F50X-S)
			65.	CHM308	RH Storage Bracket

NOTE: * (MEANS NOT SHOWN)

HYDRAULIC POLE CIRCUIT

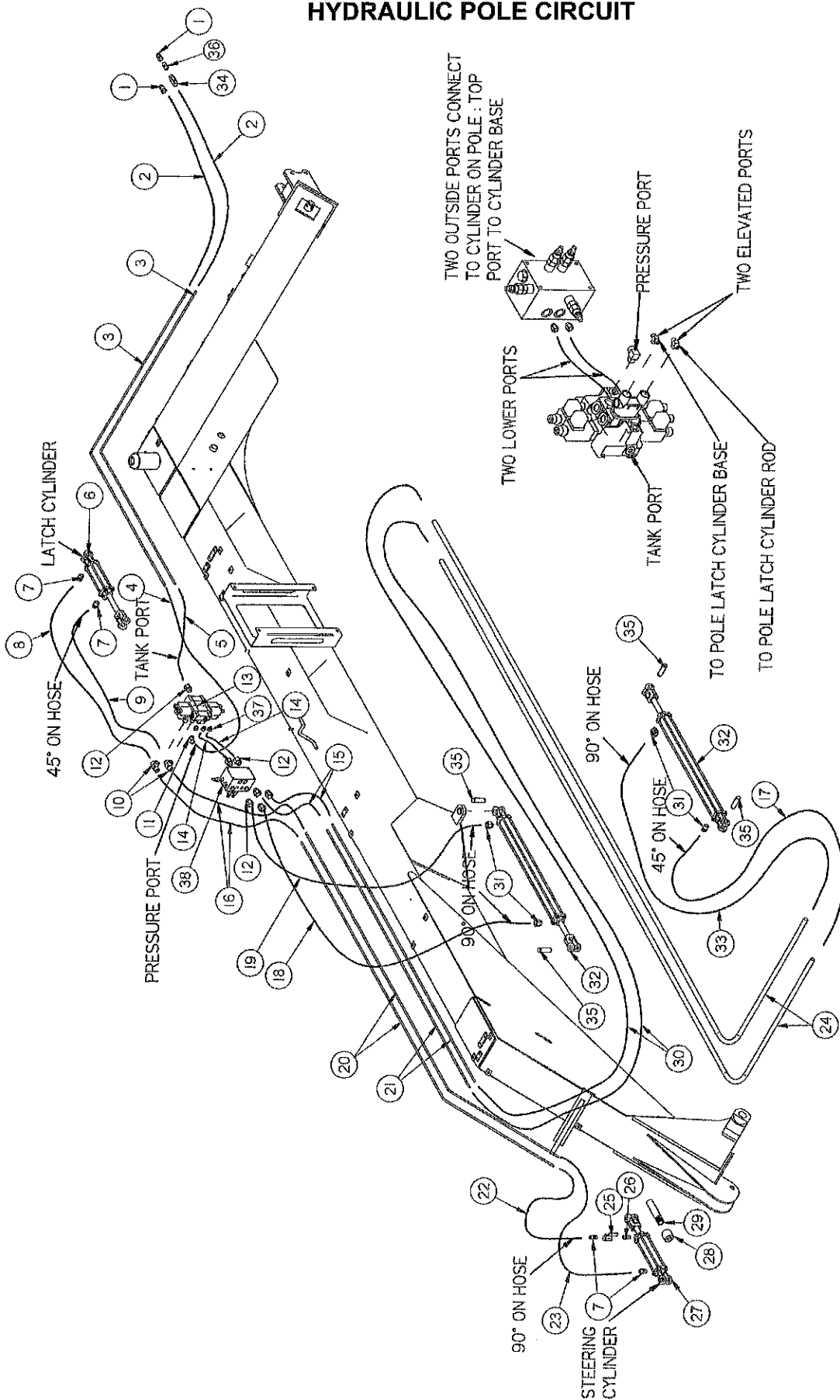
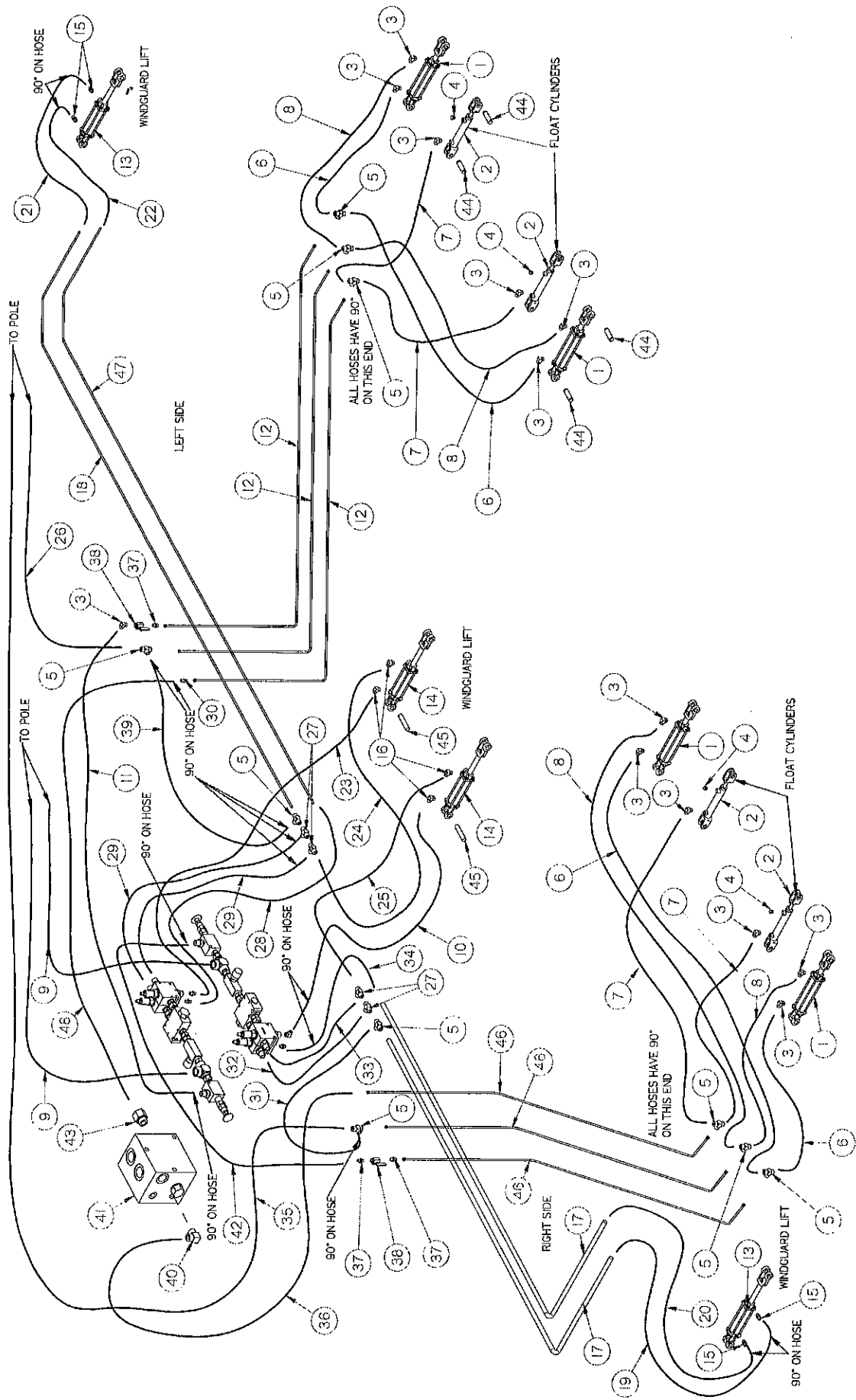

FIGURE 14
HYDRAULIC POLE CIRCUIT

ITEM	PART NO.	DESCRIPTION
1.	DWM205	1/2" Male Quick Coupler
2.	CHM198	Hydraulic Hose 104"
3.	CHM199	Hydraulic Line
4.	CHM200	Hydraulic Hose 32"
5.	CHM201	Hydraulic Hose 25"
6.	CHM107	Hydraulic Cylinder
7.	CHM202	Male Connector (6-6 FTX-S)
8.	CHM203	Hydraulic Hose 52"
9.	CHM204	Hydraulic Hose 52"
10.	CHM205	Tee Branch (6 S50X-S)
11.	CHM206	Elbow (6-8 C50X-S)
12.	CHM207	Connector (6-8 F50X-S)
13.	CHM208	Valve
*	CHM209	Solenoid
14.	CHM210	Hydraulic Hose 17"
15.	CHM211	Hydraulic Hose 36"
16.	CHM212	Hydraulic Hose 54"
17.	CHM213	Hydraulic Hose 18"
18.	CHM214	Hydraulic Hos 124"
19.	CHM215	Hydraulic Hose 60"
20.	CHM216	Hydraulic Line
21.	CHM217	Hydraulic Line
22.	CHM218	Hydraulic Hose 41"
23.	CHM219	Hydraulic Hose 34"
24.	CHM220	Hydraulic Line
25.	16SV338	3/8" Ball Valve
26.	CHM221	Nipple (3/8 FF-S)
27.	BFR69A	Hydraulic Cylinder (2" X 8")
28.	CHM135	Steering Stop Outside
29.	CHM134	Steering Stop Inside
30.	CHM222	Hydraulic Hose 99"
31.	CHM223	Male Connector (6-8 FTX-S)
32.	HD136	Hydraulic Cylinder (3-1/2" X 60")
33.	CHM224	Hydraulic Hose 87"
34.	CHM269	Check Valve (C20-8-FP-7)
35.	T135	Cylinder Pin
36.	WM141	Nipple Nut (5404-8-8)
37.	CHM301	Connector (6 F50S-X)
38.	CHM302	Sequence Manifold

NOTE: * (MEANS NOT SHOWN)

FIGURE 15



**FIGURE 15
HYDRAULIC PICKUP CIRCUIT**

ITEM	PART NO.	DESCRIPTION	ITEM	PART NO.	DESCRIPTION
1.	CHM107	Hydraulic Cylinder (2" X 6")	25.	CHM240	Hydraulic Hose 96"
2.	CHM125	Hydraulic Cylinder (1-1/4" X 6")	26.	CHM241	Hydraulic Hose 140"
3.	CHM164	Male Elbow (6-6 CTX-S)	27.	CHM242	Tee Swivel Run (6 R6X-S)
4.	BFR70	Vent Plug	28.	CHM243	Hydraulic Hose 53"
5.	CHM225	Union Tee (6 JTX-S)	29.	CHM244	Hydraulic Hose 47"
6.	CHM226	Hydraulic Hose 88"	30.	CHM258	Jig Union (6HTX-6)
7.	CHM227	Hydraulic Hose 84"	31.	CHM245	Hydraulic Hose 23"
8.	CHM168	Hydraulic Hose 94"	32.	CHM246	Hydraulic Hose 13"
9.	CHM228	Hydraulic Hose 87"	33.	CHM247	Hydraulic Hose 19"
10.	CHM295	Hydraulic Hose 86"	34.	CHM248	Hydraulic Hose 48"
11.	CHM230	Hydraulic Hose 75"	35.	CHM249	Hydraulic Hose 91"
12.	CHM231	Hydraulic Line	36.	CHM250	Hydraulic Hose 21"
13.	CHM152	Hydraulic Cylinder (3" X 6")	37.	CHM202	Male Connector (6-6 FTX-S)
14.	CHM108	Hydraulic Cylinder (3" X 6")	38.	16SV338	3/8" Ball Valve
15.	CHM223	Male Connector (6-8 FTX-S)	39.	CHM251	Hydraulic Hose 30"
16.	CHM232	Elbow (6-8 CTX-S)	40.	CHM206	Elbow (6-8 C50X-S)
17.	CHM220	Hydraulic Line	41.	CHM195	Manifold
18.	CHM234	Hydraulic Line	42.	CHM253	Hydraulic Hose 33"
19.	CHM235	Hydraulic Hose 44"	43.	CHM207	Connector (6-8 F50X-S)
20.	CHM236	Hydraulic Hose 37"	44.	T134	Cylinder Pin
21.	CHM218	Hydraulic Hose 41"	45.	CHM92	Pivot Pin
22.	CHM237	Hydraulic Hose 34"	46.	CHM223	Hydraulic Line
23.	CHM238	Hydraulic Hose 99"	47.	CHM252	Hydraulic line
24.	CHM239	Hydraulic Hose 81"	48.	CHM255	Hydraulic Hose 56"

HYDRAULIC PICKUP POLE CIRCUIT

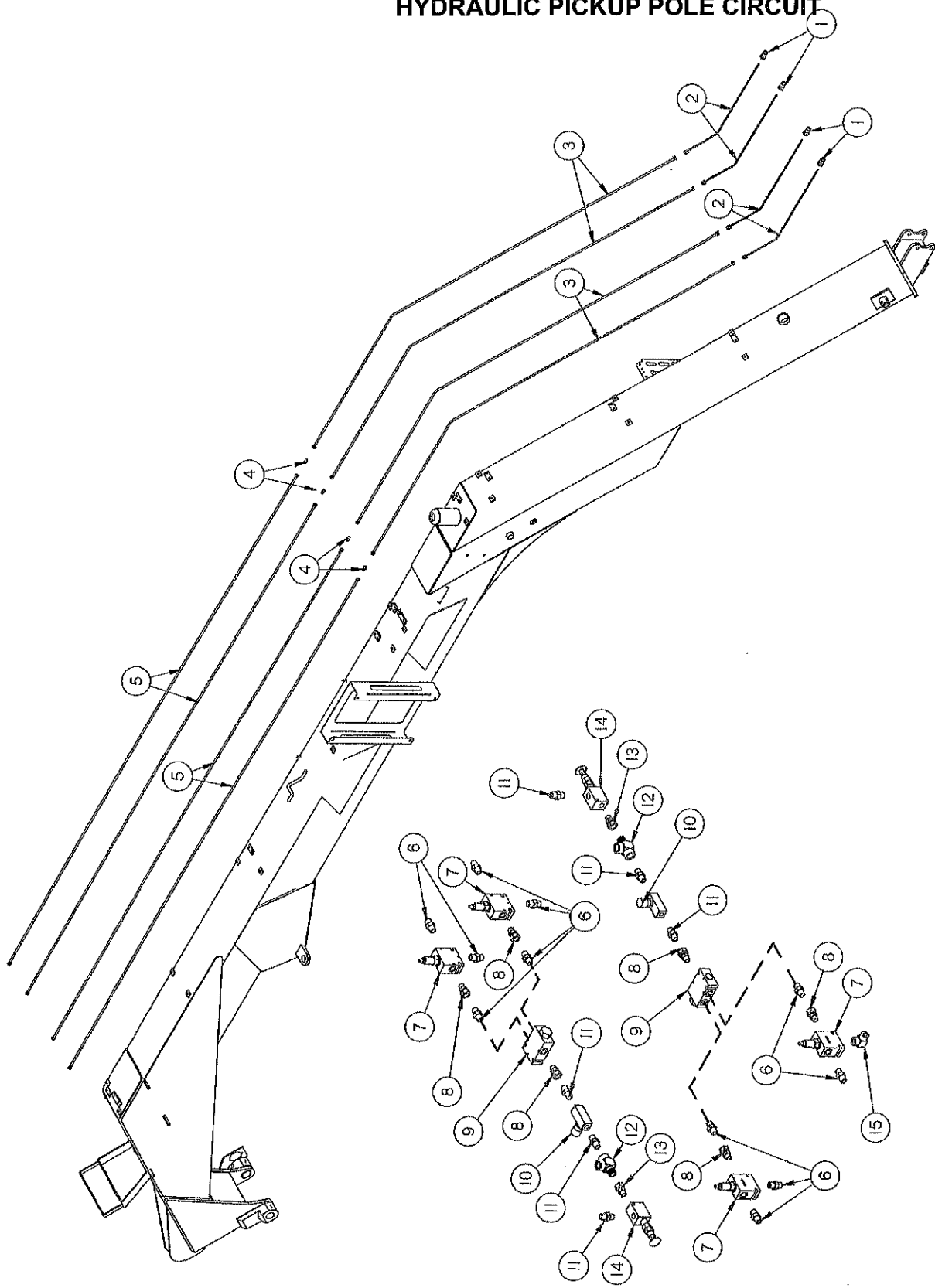

FIGURE 16
HYDRAULIC PICKUP POLE CIRCUIT

ITEM	PART NO.	DESCRIPTION
1.	DWM205	1/2" Male Quick Coupler
2.	CHM198	Hydraulic Hose 104"
3.	CHM199	Hydraulic Line
4.	CHM258	Union (6 HTX-S)
5.	CHM259	Hydraulic Line
6.	CHM257	Connector (6 F50X-S)
7.	CHM260	Counter Balance Valve
*	CHM261	Valve Cartridge
8.	CHM262	Connector Swivel (6 F650X-S)
9.	CHM263	Flow Divider
*	CHM264	Valve Cartridge
10.	CHM265	Flow Control
11.	CHM202	Male Connector (6-6 FTX-S)
12.	CHM242	Tee Swivel Run (6 R6X-S)
13.	CHM266	Connector Swivel Male (6-6 F6X-S)
14.	16SV339	Sequence Valve
*	CHM328	Valve Cartridge
15	CHM268	Elbow (6 C50X-S)

NOTE: * (MEANS NOT SHOWN)

FIGURE 17

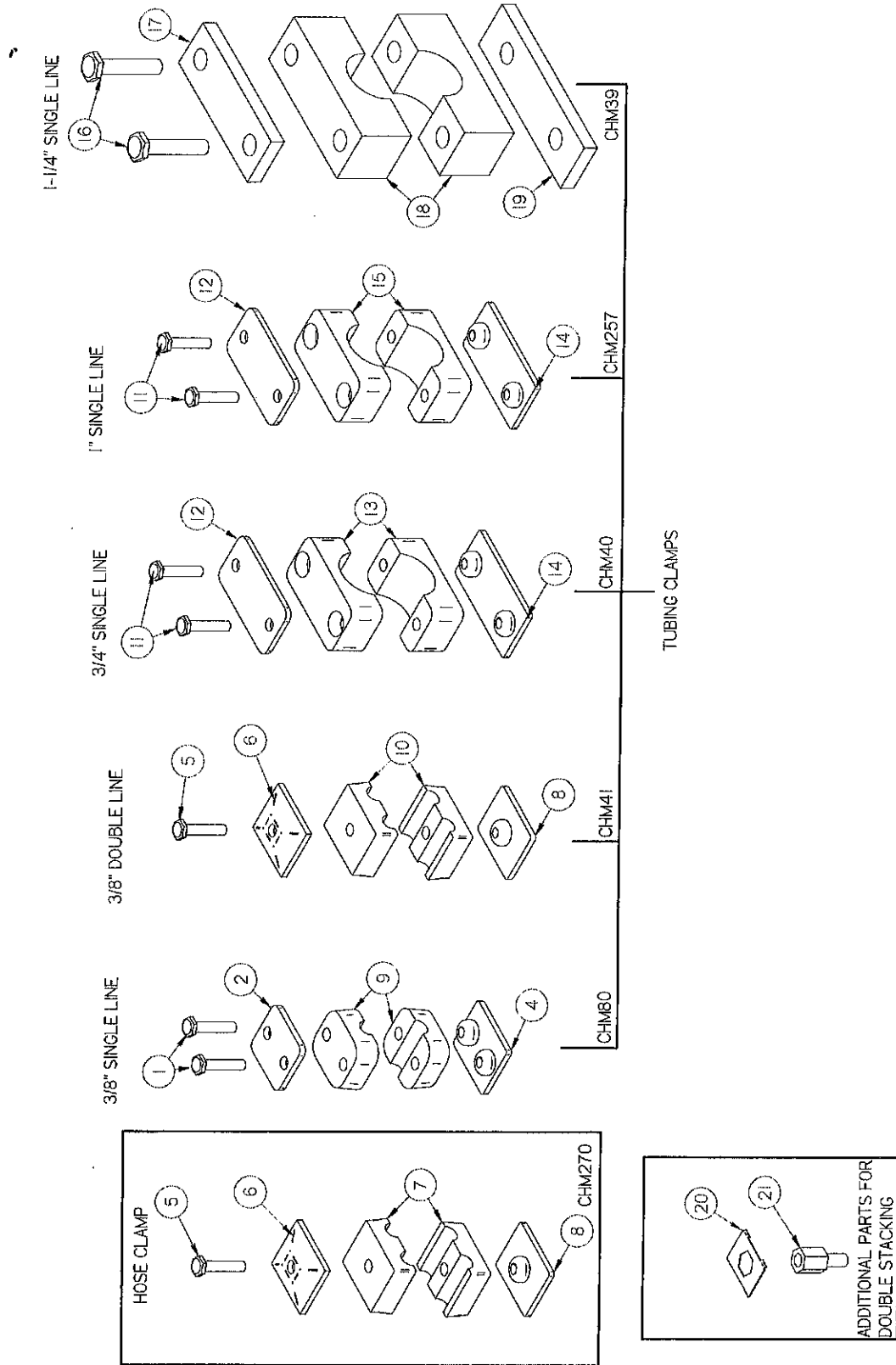

FIGURE 17
HYDRAULIC HOSE & TUBE CLAMPS

ITEM	PART NO.	DESCRIPTION
1.	CHM272	Hex Bolt
2.	CHM273	Cover Plate
4.	CHM275	Weld Plate
5.	CHM276	Hex Bolt
6.	CHM277	Cover Plate
7.	CHM278	Clamp Halves 3/8" Hose
8.	CHM279	Weld Plate
9.	CHM280	Clamp Halves 3/8" Tube
10.	CHM281	Clamp Halves 3/8" Tube
11.	CHM282	Hex Bolt
12.	CHM283	Cover Plate
13.	CHM284	Clamp Halves 3/4" Tube
14.	CHM285	Weld Plate
15.	CHM286	Clamp Halves 1" Tube
16.	CHM287	Hex Bolt
17.	CHM288	Cover Plate
18.	CHM289	Clamp Halves 1-1/4" Tube
19.	CHM290	Weld Plate
20.	CHM43	Safety Plate 3/8" Double Line
*	CHM293	Safety Plate 3/8" Single Line
*	CHM291	Safety Plate 3/4" & 1" Single Line
21.	CHM42	Stacking Bolt 3/8" Clamp Double Line
*	CHM294	Stacking Bolt 3/8" Clamp Single Line
*	CHM292	Stacking Bolt 3/4" & 1" Clamp Single Line

COMPLETE CLAMPS

*	CHM270	3/8" Hose Clamp (Double)
*	CHM80	3/8" Line Clamp (Single)
*	CHM41	3/8" Line Clamp (Double)
*	CHM40	3/4" Line (Single)
*	CHM303	1" Line Clamp (Single)
*	CHM39	1-1/4" Line Clamp (Single)

FIGURE 18

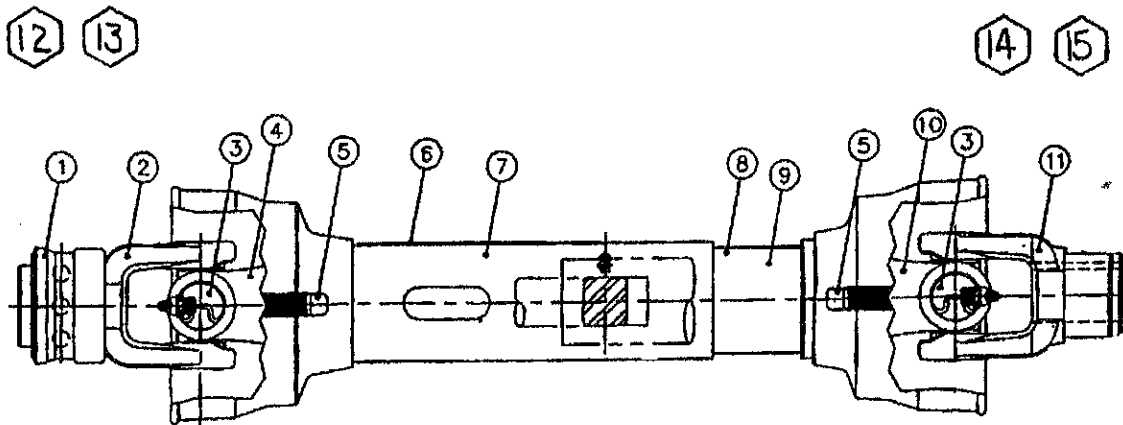

**FIGURE 18
PTO ASSEMBLY**

ITEM	PART NO.	DESCRIPTION
1.	S225	Spring Lock Repair Kit
2.	37N73	Spring Lock Yoke Assmby # 14121-1012
3.	14NW KIT	Cross & Bearing Kit (14R)
4.	DWM289	Yoke & Shaft
5.	4N20	Nylon Repair Kit
6.	DWM290	Safety Sign
7.	DWM291	Outer Guard
8.	DWM292	Inner Guard
9.	DWM293	Safety Sign (Not Shown)
10.	DWM294	Yoke, Tube & Slip Sleeve
11.	DWM295	Yoke
12.	DWM296	Joint & Shaft Half Assembly W/Guard
13.	DWM297	Joint & Shaft Half Assembly
14.	DWM298	Joint & Shaft Half Assembly W/Guard
15.	DWM299	Joint & Shaft Half Assembly
*	DWM300	Complete PTO

NOTE: * (MEANS NOT SHOWN)

PAGE NOT USED AT THIS TIME

